

# **SHARPE<sup>®</sup> VALVES**

---

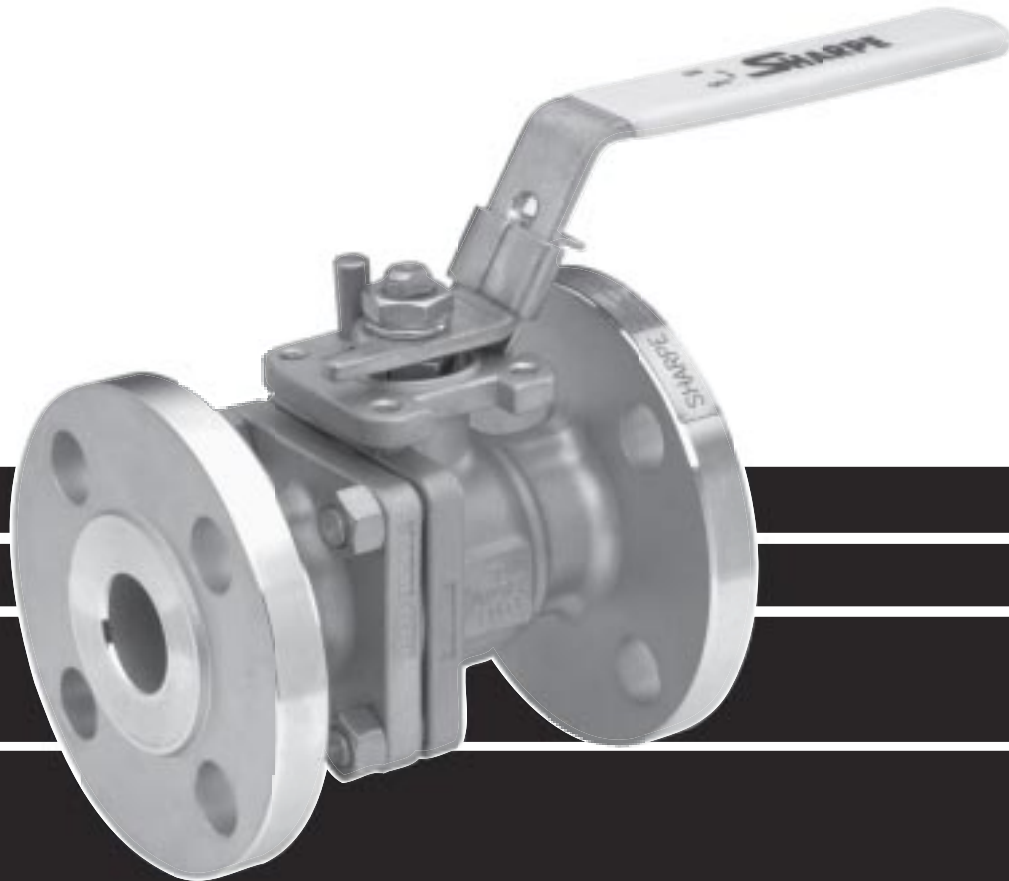

**SERIES FS50**  
**FIRE SAFE FULL PORT FLANGED BALL VALVES**  
**CLASS 150/300/600**

# SHARPE® FIRE SAFE API 607, 4<sup>th</sup> EDITION FULL PORT FLANGED BALL VALVES

---

Sharpe Series FS50 full port flanged ball valves offer as standard features, advantages that other manufacturers only offer as costly extras. This is the Sharpe® advantage.

## **Fire Safe – API 607 4th Edition**

Series FS50 flanged valves have been qualified by testing to API Standard 607, 4th Edition. The valve design incorporates a secondary metal seat in the body, providing the required shutoff should the seats be destroyed by fire.

## **ASME B16.34 Design**

Full port, split body design meets all requirements of ASME B16.34 for Class 150, 300, and 600 ball valves.

## **Blow-out proof, Heavy-Duty Stem**

The internal-entry stem is machined with a heavy shoulder to prevent blowout. All Class 600 stems are machined from high-strength 17-4PH stainless steel as a standard material.

## **Anti-static Configuration**

Anti-static devices are included at two points on the valve stem to provide continuous ball-to-stem and stem-to-body grounding, to prevent build-up of static charge in the valve, and potential sparking conditions.

## **Live-loaded Stem Seals**

Stem seals are live-loaded using Belleville springs to provide consistent sealing forces, reducing or eliminating the need for frequent seal adjustment.

## **Fully Encapsulated Body Seals**

Provides consistent and controlled loading of the body seal compression through a full metal-to-metal contact joint design, eliminating seal extrusion and potential body joint leakage.

## **Integral Mounting Pad**

Ideal for actuation. ISO 5211 mounting dimensions simplify fit and alignment between valve, bracketry, and actuator. Permits easy field conversion from manual operation to power actuation.

## **Latching/Locking Handle**

All Sharpe Series 50 ball valves supplied with lever handles are designed to permit locking the valve in either the open or closed position. Sizes through 2" are supplied with a slide latch engaged at open and closed positions to prevent inadvertent operation.

## **Slotted Seat Design**

Relief slots are provided at the perimeter of the seats to equalize pressure in the body cavity with the upstream line when valve is closed, preventing upstream seat extrusion and enhancing downstream seating performance.

## **Choice of Seats and Seals**

A variety of seat materials is available for the most demanding applications, including TFE, RTFE, TFM™, and NOVA. Stem packing and body seals are die-formed flexible graphite.

## **Floating Ball Design**

Precision engineered and machined solid stainless steel ball with relief hole in the stem slot prevents build-up of cavity pressure while the valve is in the open position.

## **Material Traceability**

Body and end piece castings are marked with heat codes providing traceability to the chemical analysis and material test reports performed at the foundry. CMTR's (Certified Material Test Reports) are available upon request.

## **Fugitive Emissions Testing**

Sharpe Ball Valves have been tested in accordance with ANSI/ISA-S93.00.01-1999 for fugitive emissions, which includes thermal cycling as well as mechanical cycling, and achieved a Leak Rate Category of 75 PPM. Details of testing, and test reports or certifications are available from on request from Sharpe Valves.

# SERIES FS50 VALVE PARTS AND IDENTIFICATION

**CLASS 150/300/600  
FIRE SAFE API 607 4th EDITION  
BLOW OUT PROOF STEM  
ANTI-STATIC DEVICE  
10" AND 12" SUPPORTED BALL 150#  
6" THRU 12" SUPPORTED BALL 300#**

APPLICABLE STANDARDS	
Wall Thickness	ASME B 16.34
Face to Face Dimensions	ASME B 16.10
Flange Dimensions	ASME B 16.5
NACE	MR-01-75
Fire Safe	API 607 4th Edition
Pressure Testing	ASME B 16.34 API 598 (Optional)
Basic Design	ASME B16.34

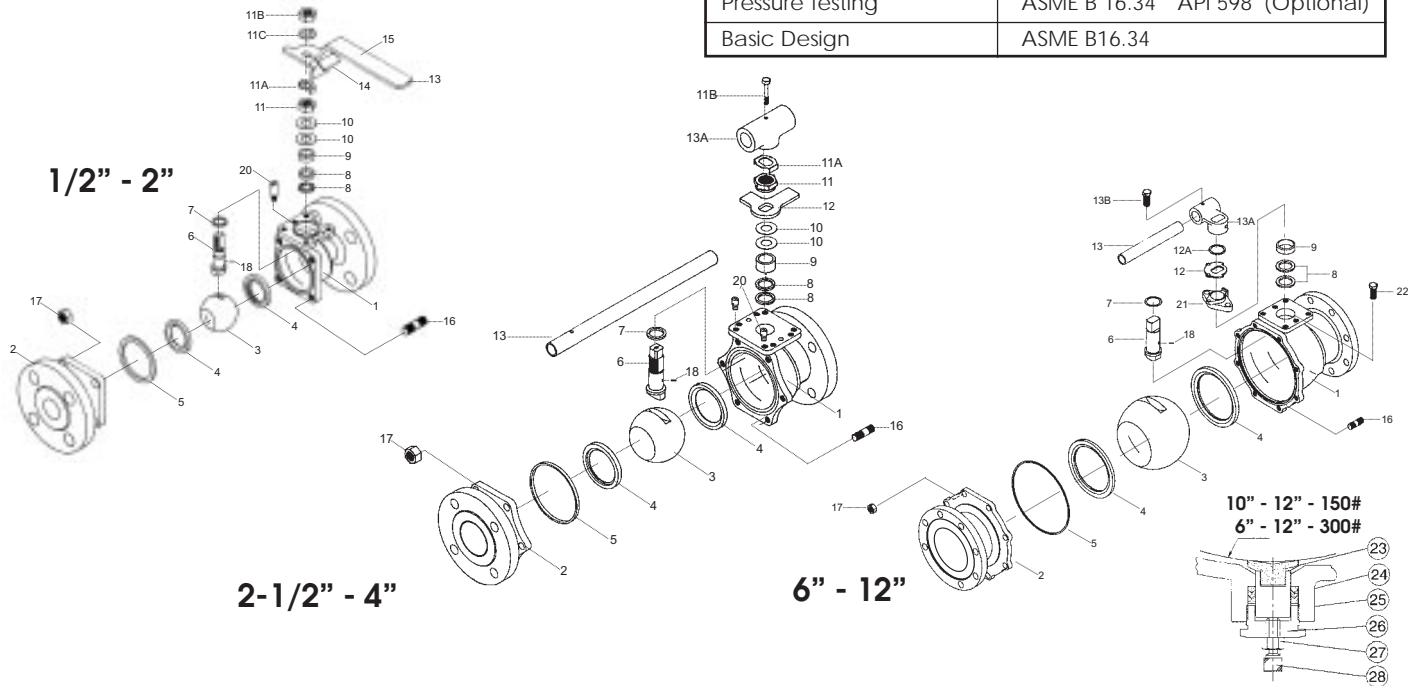

PART NO.	PART	QTY.	MATERIAL
1	Body	1	316 Stainless Steel ASTM A351 CF8M Alloy 20 ASTM A351 CN7M Carbon Steel ASTM A216 WCB Hastelloy C ASTM A494 Gr. CW-12MW Monel ASTM A494 Gr. M35-1
2	End Connector	1	316 Stainless Steel ASTM A351 CF8M Alloy 20 ASTM A351 CN7M Carbon Steel ASTM A216 WCB Hastelloy C ASTM A494 Gr. CW-12MW Monel ASTM A494 Gr. M35-1
3	Ball	1	316 Stainless Steel Alloy 20 Hastelloy C Monel
4	Seat	2	RTFE / NOVA / TFE / TFM
5	Body Seal	1	Flexible Graphite
6	Stem	1	316 Stainless Steel Alloy 20 Hastelloy C Monel 17-4PH Standard in 600# Option in 150# & 300#
7	Thrust Bearing	2	Reinforced TFE
8	Stem Packing	2	Flexible Graphite
9	Gland Packing	1	304 Stainless Steel
10	Belleville Washer (1/2"-4")	2/4	304 Stainless Steel
11	Packing Nut (1/2"-4")	1	304 Stainless Steel
11A	Lock Tab	1	Stainless Steel
11B	Handle Nut	1	304 Stainless Steel
11C	Lock Washer (1/2"-2")	1	304 Stainless Steel (1/2"-2")
12	Stopper	1	304 Stainless Steel
13	Handle	1	304 Stainless Steel (1/2"-2") Galvanized Steel (2-1/2"-4") Ductile Iron (6"-8")
13A	Wrench Block	1	304 Stainless Steel (2-1/2"-4") Ductile Iron (6"-8")
13B	Handle Nut	1	304 Stainless Steel

PART NO.	PART	QTY.	MATERIAL
14	Locking Device (1/2"-2")	1	304 Stainless Steel
15	Sleeve	1	Vinyl
16	Body Stud	SEE* N	A193 ASTM A193, Gr. B8M (Stainless Steel) A193 ASTM A193, Gr. B7 (Carbon Steel)
17	Nut	SEE* N	A194 ASTM A194, Gr. 8 (Stainless Steel) A194 ASTM A194, Gr. 2H (Carbon Steel)
18	Anti Static Device	2	316 Stainless Steel
20	Stop Pin (1/2"-2") (2-1/2"-4")	1 2	304 Stainless Steel 304 Stainless Steel
21	Gland Flange 6" - 12"	1	316 Stainless Steel Carbon Steel
22	Gland Bolts (6"-12")	2	304 Stainless Steel
23	Supporter Seat (10"-12") 150# (6"-12") 300#	1	Reinforced TFE
24	Packing (10"-12") 150# (6"-12") 300#	3	Flexible Graphite
25	Supporter (10"-12") 150# (6"-12") 300#	1	304 Stainless Steel
26	Bushing (10"-12") 150# (6"-12") 300#	1	304 Stainless Steel
27	Bushing Nut (10"-12") 150# (6"-12") 300#	1	304 Stainless Steel
28	Adjust Screw (10"-12") 150# (6"-12") 300#	1	304 Stainless Steel

\*See Dimensions

# SERIES FS50 DIMENSIONS

1/2" - 2"

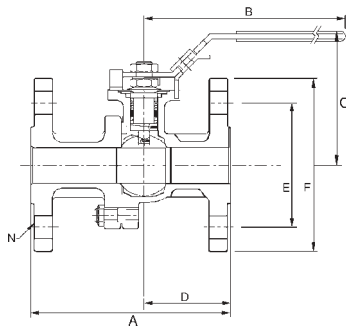

2-1/2" - 4"

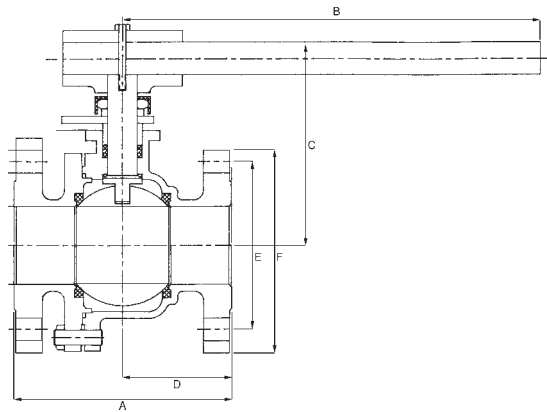

6" - 12"

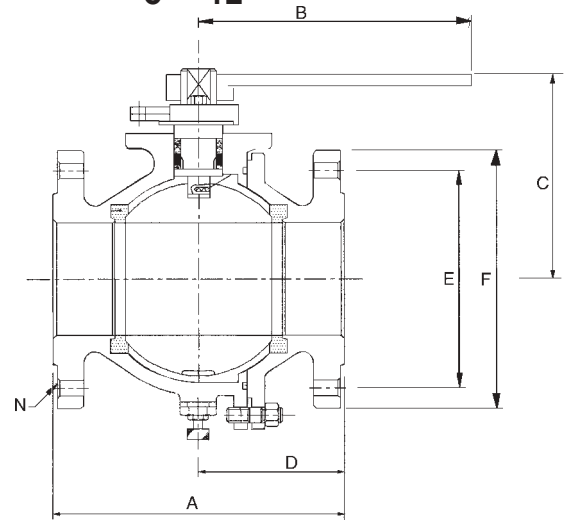

SIZE	A			B			C			D			E			F			N			G		
CLASS	150	300	600	150	300	600	150	300	600	150	300	600	150	300	600	150	300	600	150	300	600	150	300	600
1/2"	4.25	5.50	6.50	6.50	6.50	4.98	2.60	2.60	3.75	1.80	2.44	3.25	2.38	2.62	2.62	3.50	3.75	3.75	4	4	4	1.39	1.39	1.39
3/4"	4.62	6.00	7.50	6.50	6.50	4.98	2.91	2.92	3.68	2.00	2.72	3.40	2.75	3.25	3.25	3.85	4.62	4.62	4	4	4	1.39	1.39	1.39
1"	5.00	6.50	8.50	7.87	7.87	5.77	3.45	3.43	3.80	2.12	2.92	4.25	3.13	3.50	3.50	4.25	6.12	4.88	4	4	4	1.39	1.39	1.39
1-1/2"	6.50	7.50	9.50	9.85	9.85	7.54	4.20	4.15	4.63	2.76	3.26	4.75	3.56	4.50	4.50	5.00	6.15	6.12	4	4	4	1.94	1.94	1.95
2"	7.00	8.50	11.50	10.45	10.50	7.54	4.50	4.53	5.00	3.08	3.94	5.47	4.75	5.00	5.00	6.00	6.50	6.50	4	8	8	1.94	1.94	1.95
2-1/2"	7.50	9.50	-	13.75	13.75	-	6.70	6.70	-	3.09	4.05	-	5.50	5.86	-	7.00	7.50	-	4	8	-	2.84	2.84	-
3"	8.00	11.12	14.00	13.75	13.75	13.75	7.00	7.00	7.20	3.74	5.40	6.18	6.00	6.62	6.62	7.48	8.25	8.25	4	8	8	2.84	2.84	2.84
4"	9.00	12.00	17.00	13.75	13.75	13.75	7.70	7.70	7.96	4.46	5.93	8.64	7.50	7.88	8.50	9.01	10.00	10.74	8	8	8	2.84	2.84	2.84
6"	15.50	15.87	-	38.97	38.97	-	11.22	11.22	-	7.61	7.60	-	9.50	10.63	-	10.98	12.50	-	8	12	-	3.48	3.48	-
8"	18.00	19.75	-	38.97	38.97	-	11.57	12.71	-	8.34	9.33	-	11.75	13.00	-	13.50	15.00	-	8	12	-	3.48	3.48	-
10"	21.00	22.37	-	**	**	-	13.70	15.28	-	10.47	11.18	-	14.25	15.25	-	15.98	17.50	-	12	16	-	3.90	3.48	-
12"	24.00	25.51	-	**	**	-	13.50	15.08	-	12.00	12.80	-	17.00	17.75	-	19.01	20.50	-	12	16	-	3.90	3.90	-

SIZE	H			I			J			K			W			PORT			WEIGHT				
CLASS	150	300	600	150	300	600	150	300	600	150	300	600	150	300	600	150	300	600	150	300	600		
1/2"	3/8-24 UNF			1/2- 20 UNF			0.22	0.295	0.28	0.28	0.49	0.63	0.63	0.74	M5	M5	M6	0.59	0.59	0.59	4	5	6
3/4"	3/8-24 UNF			1/2-20 UNF			0.22	0.295	0.28	0.28	0.49	0.63	0.63	0.79	M5	M5	M6	0.78	0.78	0.78	6	7	8
1"	7/16-20 UNF			9/16-18 UNF			0.30	0.393	0.30	0.30	0.61	0.90	0.90	0.83	M6	M6	M6	1.00	1.00	1.00	8	10	11.5
1-1/2"	9/16-18 UNF			3/4-16 UNF			0.35	0.472	0.42	0.42	0.84	1.18	1.18	1.22	M8	M8	M8	1.50	1.50	1.50	15	19	22
2"	9/16-18 UNF			3/4-16 UNF			0.35	0.472	0.42	0.42	0.84	1.18	1.18	1.22	M8	M8	M8	2.00	2.00	2.00	20	33	38
2-1/2"	1-14 UNS			-			0.55	-	0.55	0.55	-	1.83	1.83	-	M10	M10	-	2.55	2.55	-	36	50	-
3"	1-14 UNS			1-20 UNF			0.745	0.745	0.66	0.66	0.69	1.83	1.83	1.67	M10	M10	M10	3.00	3.00	3.00	45	68	78
4"	1-14 UNS			1-14 UNS			0.745	0.745	0.66	0.66	0.69	1.83	1.83	1.83	M10	M10	M10	4.00	4.00	4.00	75	96	146
6"	1.72			-			1.03	-	1.60	2.15	-	3.35	3.35	-	M12	M12	-	6.00	6.00	-	135	230	-
8"	1.72			-			1.03	-	2.13	1.60	-	3.86	3.86	-	M12	M12	-	7.88	7.88	-	290	430	-
10"	1.96			-			1.38	-	2.15	2.17	-	3.74	3.91	-	M16	M16	-	9.84	9.84	-	540	810	-
12"	1.96			-			1.38	-	2.15	2.17	-	3.74	3.82	-	M16	M16	-	11.81	11.81	-	660	902	-

\*\* Gear Operator

1/2" - 4"

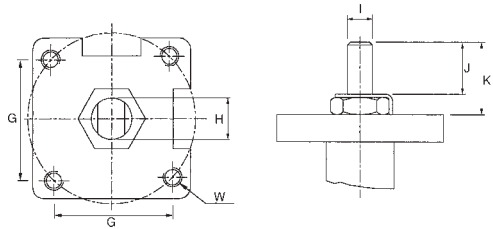

6" - 12"

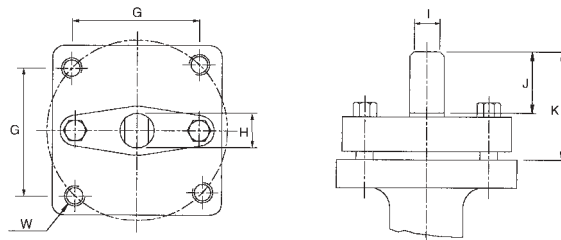

**GEAR OPERATOR**

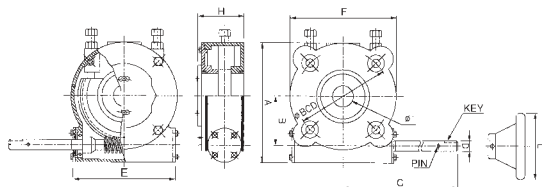

**GEAR DIMENSIONS**

Figure G04 For 10" & 12" Valve / #150

A	11.26
B	4.63
C	10.01
D	1.00
E	9.25
F	10.00
H	4.72
L	12.60
BRACKET HT.	5.28
WEIGHT	110

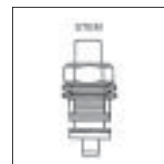

1/2" - 4"  
STEM ARRANGEMENT FOR ACTUATORS

**Cv DATA**

1/2"	26
3/4"	50
1"	94
1-1/2"	260
2"	480
2-1/2"	750
3"	1300
4"	2300
6"	5400
8"	10000
10"	15000
12"	21000

**SEAT PRESSURE/TEMPERATURE RATING SERIES FS50**

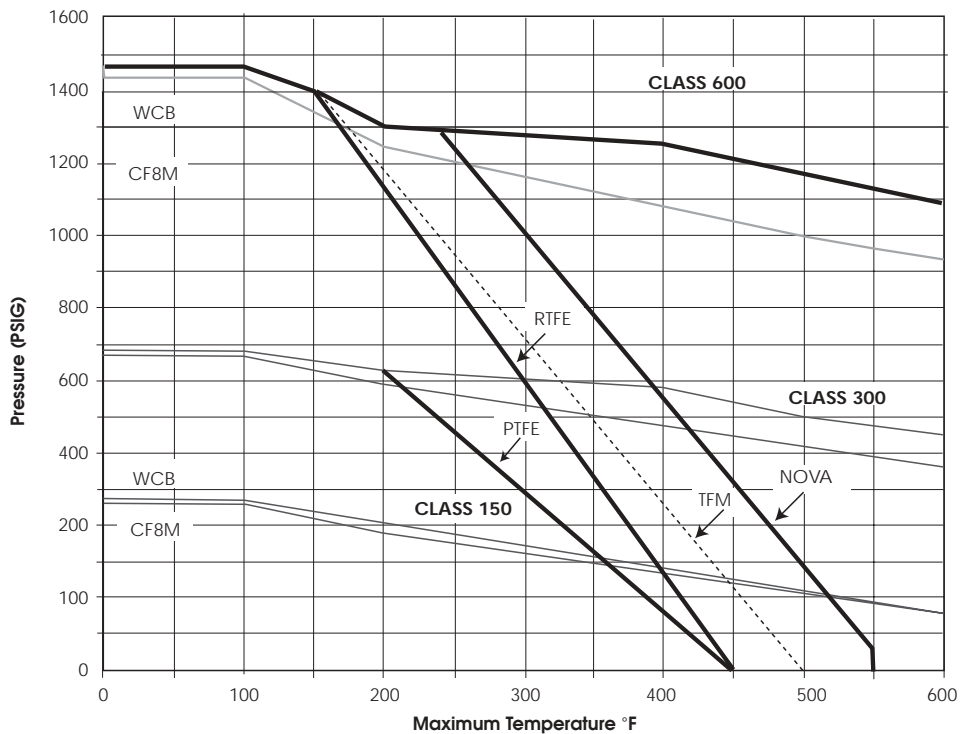

# SHARPE® VALVES

Choose from our full line of high quality valves and actuators to meet your needs.

*Whatever your flow control requirements are, Sharpe® has the right products and service to meet your needs today.*



## HOW TO ORDER

VALVE SIZE		VALVE SERIES	CLASS	ALLOY	SEATS	OPTIONS
1/2"	6"	FS50	150# = 11	2 = Alloy 20	T = TFE	X = Oxygen Service
3/4"	8"		300# = 33	4 = Carbon Steel	M = TFM™	OH = Oval Handle
1"	10"		600# = 66	5 = Hastelloy C	R = Reinforced TFE	F = Fugitive Emissions
1-1/2"	12"			6 = Stainless Steel	N = NOVA	Certified ANSI 593.00.01
2"				3 = Monel		E = Extended Stem
2-1/2"						L = Lockable Extended Stem
3"						D = Leak Detection Stem
4"						GO = Gear Operator
					7 = 17 - 4PH Stem	
					A = Nace	

**3/4" FS50 33 6 I X**

# SHARPE® VALVES

A DIVISION OF **Sharon** PIPING & EQPT., INC.

**Toll-Free 1-877-7SHARPE**

Fax: (708) 562-0890

E-Mail: [info@sharpevalves.com](mailto:info@sharpevalves.com)

[www.sharpevalves.com](http://www.sharpevalves.com)

1260 Garnet Drive

Northlake, Illinois 60164 U.S.A.