

SHARPE[®] VALVES



**SERIES N66
TUBE FULL PORT
3 PIECE BALL VALVES**

SERIES N66

VALVE PARTS AND IDENTIFICATION

ASTM A351 316L
 LIVE LOADED STEM PACKING
 BLOW OUT PROOF STEM
 ISO 5211 MOUNTING PAD
 LOCKABLE HANDLE
 1000 WOG
 TRACEABILITY

20-25 RA / 180 GRIT
 POLISH

1/2" - 4"

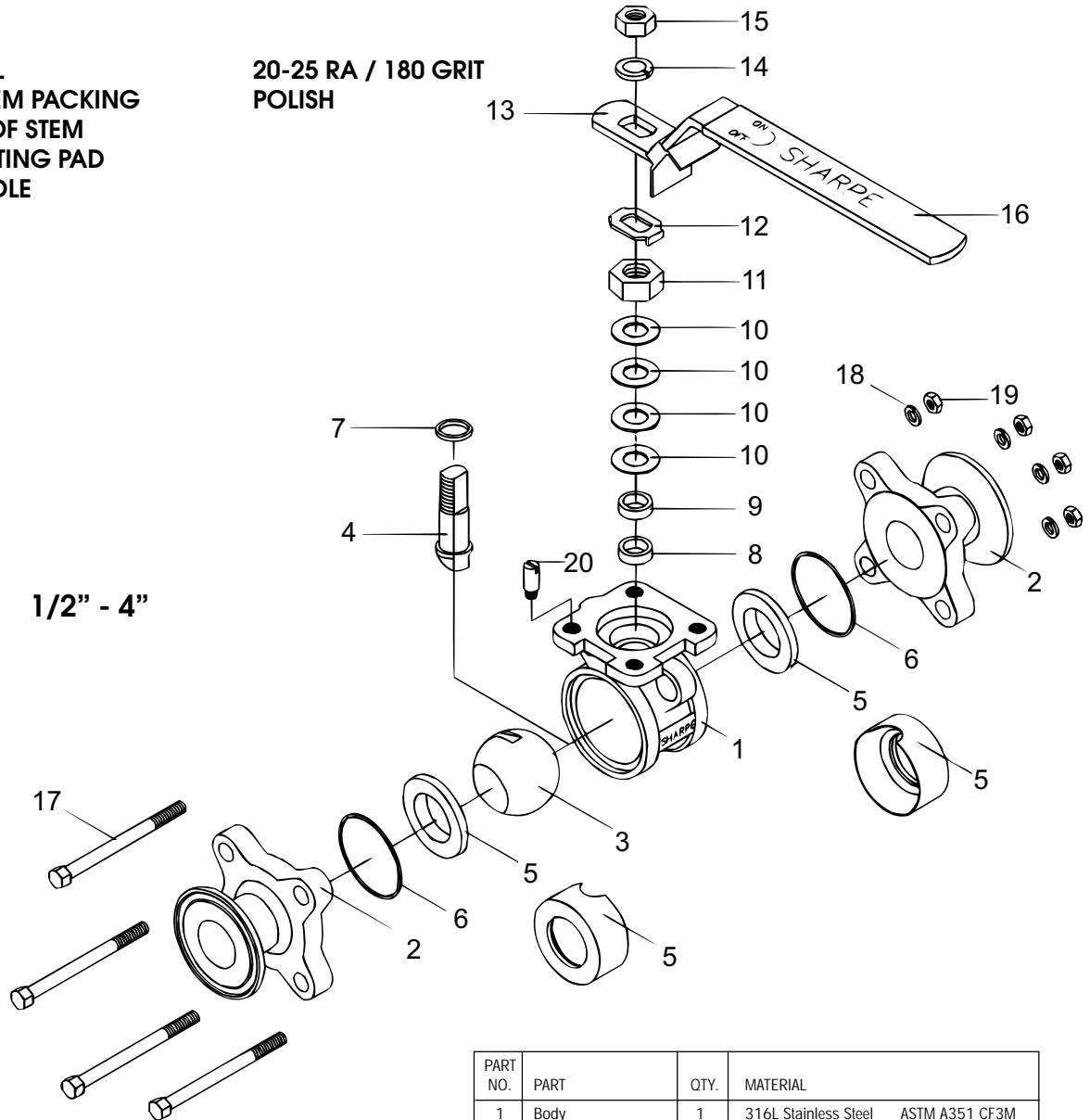

PART NO.	PART	QTY.	MATERIAL
1	Body	1	316L Stainless Steel ASTM A351 CF3M
2	Ends	2	316L Stainless Steel ASTM A351 CF3M
3	Ball	1	316L Stainless Steel ASTM A351 CF3M
4	Stem	1	316L Stainless Steel
5	Valve Seat	2	TFM / Cavity Fill PTFE
6	Valve Seal	2	PTFE
7	Thurst Bearing	1	PTFE
8	Stem Packing	1	PTFE
9	Gland Packing	1	304 Stainless Steel
10	Belleville Washer	4	304 Stainless Steel
11	Packing Nut	1	304 Stainless Steel
12	Lock Tab	1	304 Stainless Steel
13	Handle	1	304 Stainless Steel
14	Lock Washer	1	304 Stainless Steel
15	Handle Nut	1	304 Stainless Steel
16	Sleeve	1	PVC
17	Body Bolts	4	304 Stainless Steel
18	Bolt Washers	4	304 Stainless Steel
19	Nut	4	304 Stainless Steel
20	Stop Pin	1	304 Stainless Steel

SERIES N66 VALVES DIMENSIONS

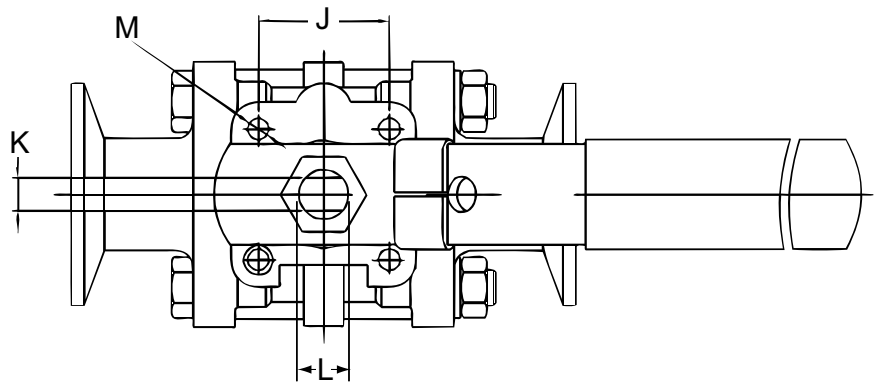
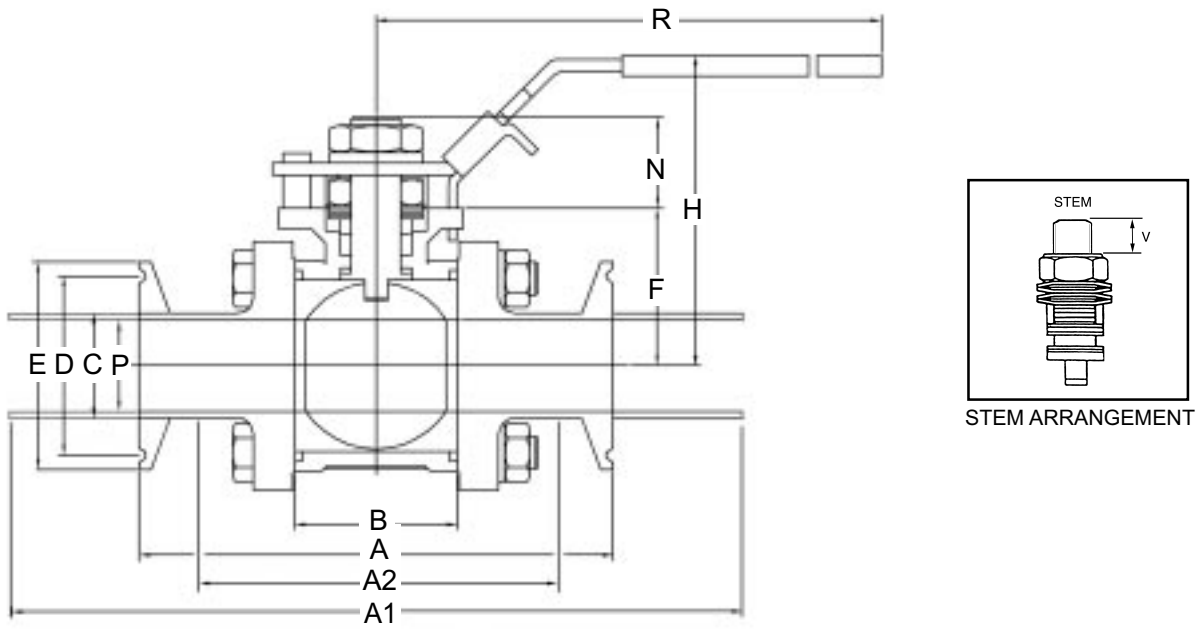

SIZE	A CE	A1 BTE	A2 BW	B	P	C	D	E	F	L	K	N	H	M	R	V	J
1/2"	3.50	5.50	2.50	0.96	0.37	0.50	0.75	0.98	1.3	3/8" -24	.22	0.65	2.44	M5	4.93	.28	1.00
3/4"	4.00	6.00	2.73	1.05	0.62	0.75	0.75	0.98	1.19	3/8" UNF	.22	0.65	2.50	M5	4.93	.28	1.00
1"	4.50	6.50	3.62	1.54	0.87	1.00	1.71	2.00	1.50	7/16" UNF	.30	0.80	2.96	M5	5.70	.30	1.16
1-1/2"	5.50	7.50	4.47	2.12	1.37	1.50	1.71	2.00	1.91	9/16" UNF	.35	1.14	3.38	M6	7.48	.42	1.39
2"	6.25	8.00	4.90	2.65	1.87	2.00	2.20	2.51	2.25	9/16" UNF	.35	1.14	3.77	M6	7.48	.42	1.39

SHARPE® VALVES

Choose from our full line of high quality valves and actuators to meet your needs.

PRESSURE TEMPERATURE RATINGS

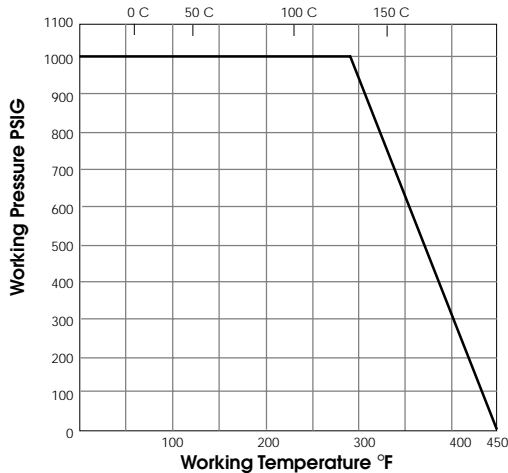

PERFORMANCE DATA

SIZE	CV	WEIGHT/LBS.*
1/2"	15	1.2
3/4"	30	2.0
1"	60	3.0
1-1/2"	130	6.0
2"	360	9.2

* TRI CLAMP ENDS

HOW TO ORDER

SIZE	SERIES	BODY	BALL & STEM	SEAT	SEAL	ENDS	OPTIONS
1/2" 3/4" 1" 1-1/2" 2" 2-1/2" 3" 4"	N66	6 = 316L Stainless Steel	6 = 316L Stainless Steel	M = TFM Seat C = PTFE Cavity Filled	T = PTFE	CE = Clamp BTE = Butt weld Tube Extended BE = Butt weld	EP = Electro Polish PP = Purge Port GO = Gear Operator X = Oxygen Service SF = Silicone Free 7 = 17 - 4 PH Stem OH = Oval Handle 2 = 240 Grit 3 = 320 Grit

1" N66 6 6 M T CE EP

SHARPE® VALVES

A DIVISION OF SHARON PIPING & EQUIP. INC.

Toll-Free 1-877-7SHARPE
E-Mail: sharpediv@aol.com
www.sharpevalves.com

504 West Wrightwood Ave.
Elmhurst, IL 60126