



2 PC Direct-Mount Automation Series



**Brass Full Port
Low Torque Design
600 WOG - 150 WSP
Temperature to 366°F**

Sizes: 1/4" thru 4"

MODELS:

- DM51 - Brass Plated Ball**
- DM52 - 316SS Ball / Stem**

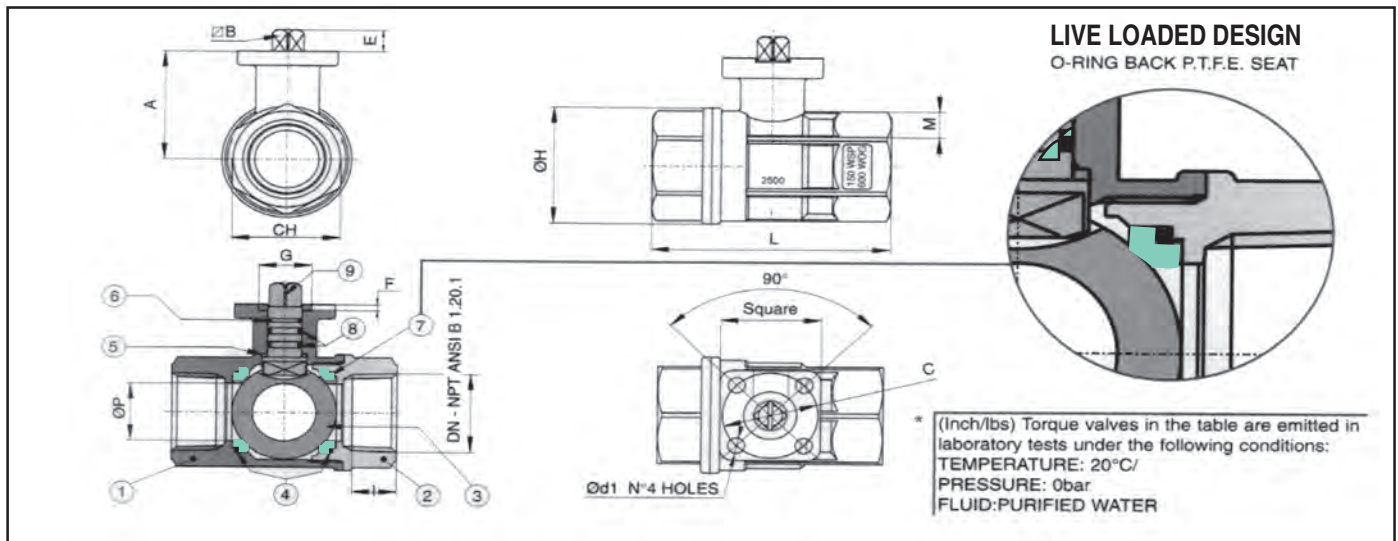

N Pos	PART NAME	MATERIALS	N PCs	SIZE	SQUARE	A	∅B	C	Ød1	E	F	ØG	ØH	I	L	CH	M	ØP	PSI	Lbs	Inch/lbs	ISO 5211
1	BODY	BRASS CW 617N UNI EN 12165	1	1/4"	1.49	1.28	0.35	1.42	0.24	0.35	0.08	0.98	1.32	0.39	2.64	1.06	0.22	0.39	600	0.82	53.10	F03
2	END CONNECTION	BRASS CW 617N UNI EN 12165	1	3/8"	1.49	1.28	0.35	1.42	0.24	0.35	0.08	0.98	1.32	0.40	2.64	1.06	0.22	0.39	600	0.79	53.10	F03
3	BALL	BRASS CW 617N UNI EN 12165	1	1/2"	1.49	1.28	0.35	1.42	0.24	0.35	0.08	0.98	1.32	0.53	2.64	1.06	0.22	0.56	600	0.66	53.10	F03
4	BALL SEAL	P.T.F.E	2	3/4"	1.49	1.28	0.35	1.42	0.24	0.35	0.08	0.98	1.57	0.55	3.00	1.26	0.22	0.75	600	0.91	53.10	F03
5	THRUST WASHER	P.T.F.E	1	1"	1.49	1.79	0.35	1.42	0.24	0.35	0.12	0.98	1.93	0.66	3.35	1.61	0.24	0.95	600	1.55	53.10	F03
6	STEM SEAL	P.T.F.E	1	1 1/4"	1.49	1.93	0.35	1.42	0.24	0.35	0.12	0.98	2.30	0.66	3.66	1.97	0.24	1.18	600	2.14	53.10	F03
7	O-RING	FKM (Viton)	2	1 1/2"	1.96	2.52	0.43	1.97	0.27	0.43	0.12	1.38	2.87	0.66	4.13	2.16	0.39	1.49	600	3.71	150.45	F05
8	O-RING	FKM (Viton)	2	2"	1.96	2.88	0.43	1.97	0.27	0.43	0.12	1.38	3.60	0.70	4.80	2.75	0.31	1.97	600	5.52	150.45	F05
9	STEM	BRASS CW 614 UNI EN 12164	1	2 1/2"	2.75	3.48	0.55	2.76	0.35	0.59	0.12	2.16	4.51	0.93	6.10	3.54	0.35	2.52	600	8.83	274.35	F07
				3"	2.75	3.85	0.55	2.76	0.35	0.59	0.12	2.16	5.35	1.01	6.89	4.13	0.35	3.00	600	13.29	274.35	F07
				4"	2.75	4.59	0.67	2.76	0.35	0.69	0.12	2.16	6.53	1.09	8.03	5.12	0.33	3.74	600	21.54	646.05	F07

Flo-Tite's "DM" design eliminates mounting brackets and all their possible related problems. Ideally designed for low profile, cost effective industrial applications.



2 PC Direct-Mount Automation Series



Stainless - Full Port
Low Torque Design
1000 WOG - 150 WSP
Temperature to 370°F
High Quality Investment Casting

Sizes: 1/2" thru 2"

MODEL: DM80SS

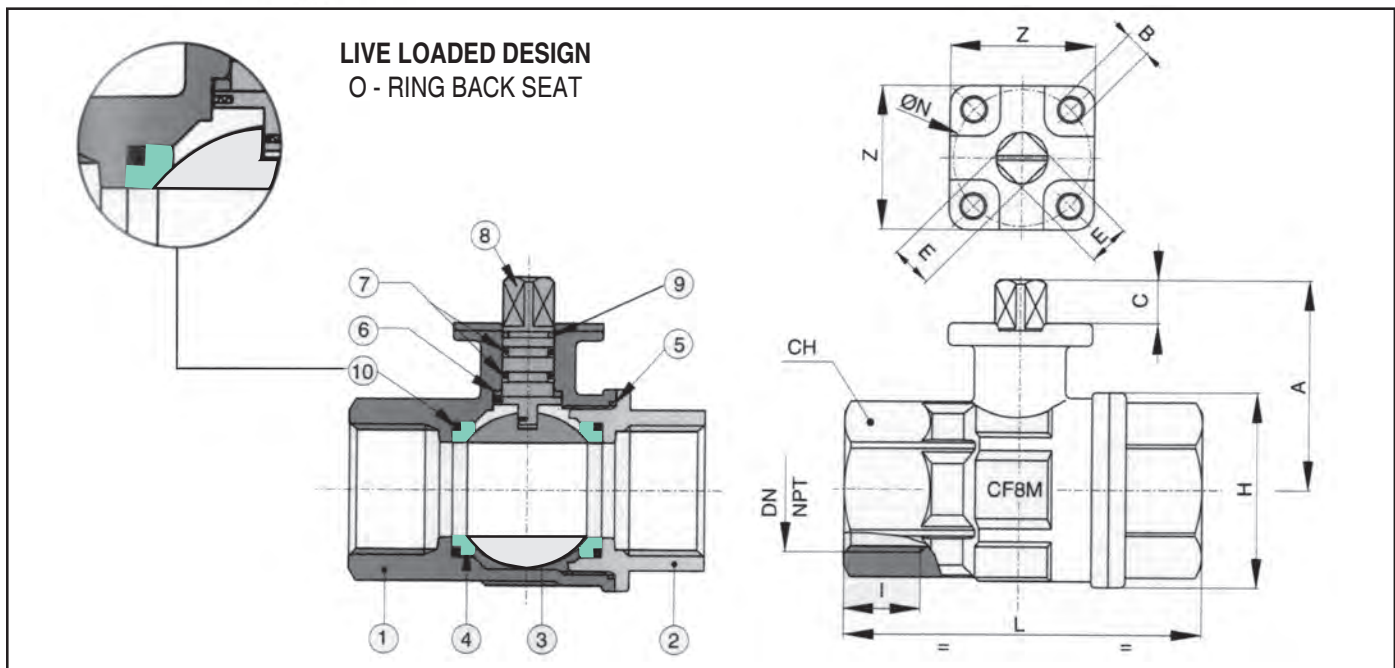

N Pos	PART NAME	MATERIALS	N PCS
1	BODY	A351 GR-CF8M	1
2	END CONNECTION	A351 GR-CF8M	1
3	BALL	AISI 316 - CF8M	1
4	BALL SEAL	P.T.F.E	2
5	SEAT	P.T.F.E	1
6	STEM SEAL	P.T.F.E	1
7	O-RING	FKM (Viton)	2
8	STEM	AISI 316 - CF8M	2
9	STEM SEAT	P.T.F.E	1
10	O-RING	FKM (Viton)	1

SIZE	I	L	H	CH	A	C	E	N	B	Z	CV	TORQUE Inch - lbs	Lbs	ISO 5211
1/2"	0.59	2.63	1.35	1.06	1.63	0.35	0.35	1.41	0.23	1.49	16.3	60	0.68	F03
3/4"	0.64	3.07	1.65	1.25	1.71	0.35	0.35	1.41	0.23	1.49	29.5	64	0.91	F03
1"	0.75	3.54	2.02	1.61	2.10	0.35	0.35	1.41	0.23	1.49	43.00	68	1.35	F03
1 1/4"	0.84	3.93	2.53	1.96	2.24	0.35	0.35	1.41	0.23	1.49	89.00	74	2.22	F03
1 1/2"	0.84	4.40	3.03	2.16	2.91	0.43	0.43	1.96	0.27	1.96	230.00	160	3.69	F05
2"	1.01	5.31	3.81	2.75	3.27	0.43	0.43	1.96	0.27	1.96	265.00	170	6.69	F05

Flo-Tite's "DM" design eliminates mounting brackets and all their possible related problems. Ideally designed for low profile, cost effective industrial applications.



P. O. Box 1293
 Lumberton, NC 28359
 Website: www.flotite.com

Tel: (910) 738-8904
 Fax: (910) 738-9112
 E-mail: flotite@nc.rr.com