

SIZE	A	B	C	D	d0	d1	ISO241	K	E	4-d2	L	D1	N-M	δ°	B1
15"	4.72	2.24	1.30	1.65	0.50	0.50	F05	2.56	1.97	0.28	1.02	3.88	4-1/2	90°	0.43
2"	5.51	2.60	1.69	2.08	0.50	0.50	F05	2.56	1.97	0.28	1.02	4.75	4-5/8	90°	0.43
2.5"	5.91	2.95	1.81	2.54	0.50	0.50	F05	2.56	1.97	0.28	1.02	5.50	4-5/8	90°	0.43
3"	6.22	3.66	1.81	3.10	0.50	0.50	F07	2.56	1.97	0.28	1.02	6.00	4-5/8	90°	0.43
4"	6.93	4.25	2.05	4.09	0.62	0.61	F07	3.54	2.76	0.39	1.10	7.50	8-5/8	45°	0.43
5"	7.48	4.92	2.20	4.85	0.74	0.74	F07	3.54	2.76	0.39	1.18	8.50	8-3/4	45°	0.55
6"	8.31	5.32	2.20	6.11	0.74	0.74	F07	3.54	2.76	0.39	1.18	9.50	8-3/4	45°	0.55
8"	9.25	6.69	2.36	7.97	0.87	0.87	F10	4.92	4.02	0.47	1.50	11.75	8-3/4	45°	0.67
10"	10.43	8.07	2.68	9.86	1.12	1.10	F10	4.92	4.02	0.47	1.50	14.25	12-7/8	30°	0.87
12"	12.00	9.37	3.07	11.87	1.24	1.10	F10	4.92	4.02	0.47	1.57	17.00	12-7/8	30°	0.87

Units: Inch

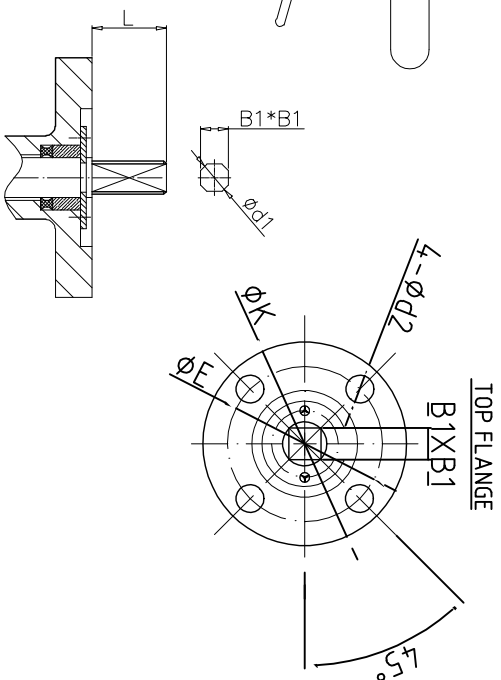

NO.	PARTS NAME	MATERIAL	QTY
8	LEVER	MALLEABLE IRON	1
7	INDICATOR	CARBON STEEL	1
6	BUSHING	PTFE	4
5	O-RING	NBR	1
4	STEM	SS410	2
3	SEAT	NBR/EPDM/VITON	1
2	DISC	DI/CF8/CF8M/Al-Bronze	1
1	BODY	C/DI	1

TEST PRESSURE	SHELL	SEAL
HYDROSTATIC	225 PSI	165 PSI
AIR		

STANDARD	DESIGN CODE	INSPECTION & TEST	END STANDARD	FACE TO FACE
	API609	API598	ANSI 150LB	API609

TITLE : LUG TYPE BUTTERFLY VALVE
DN40-DN300

APPROVED	CHECKED	DRAWN	DESIGNED	SCALE	UNIT	REV
					mm	

DWG NO. REV