



RESILIENT SEATED BUTTERFLY VALVES

Performance Series

Available in Wafer and Lug Styles

Butterfly Valves Designed for Automation & Demanding Manual Applications

Models:

Wafer 51

Lug 52

Size Range

2" thru 36"

Pressure Rating

200 WOG

250 WOG - optional



**Ductile Iron
Body, Rugged
Heavy Duty
Construction
High Quality
Epoxy Coating
for Excellent Corrosion Resistance
2-Piece Stem Design Allows for
Easy Assembly and Maintenance
with Higher Flow Capacity**

Max - Seal Concentric Butterfly Valves are backed by the resources and experience of over thirty five years of process valve and automation experience.

www.maxsealinc.com

STANDARD PARTS LIST **Sizes 2" - 14"**

NO	Part	Q'ty	Material	Code
1	Valve Body	1	Ductile Iron A536 Cast Iron Stainless Steel CF8M Bronze ASTM B62	DI CI SS BZ
2	Pin	1	Alloy Steel	
3	O-Ring	1	Buna-N	B
4	Seat Back Up	1	Phenolic	~
5	Seat	1	EPDM Buna-N - Food Grade PTFE Viton	E B T V
6	Lower Shaft	1	Stainless 416 Stainless 316	S6 SS
7	Disc	1	Nylon Coated Ductile Iron Stainless 316 CF8M Stainless 304 CF8	DI SS S4
8	Upper Shaft	1	Stainless 416 Stainless 316 17-4PH SS	S7 SS S7
9	Bushing	1	PTFE	T
10	O-Ring	1	Buna-N	B
11	Bushing	1	PTFE	T
12	Pin	1	Alloy Steel	
13	Bushing	1	PTFE	T

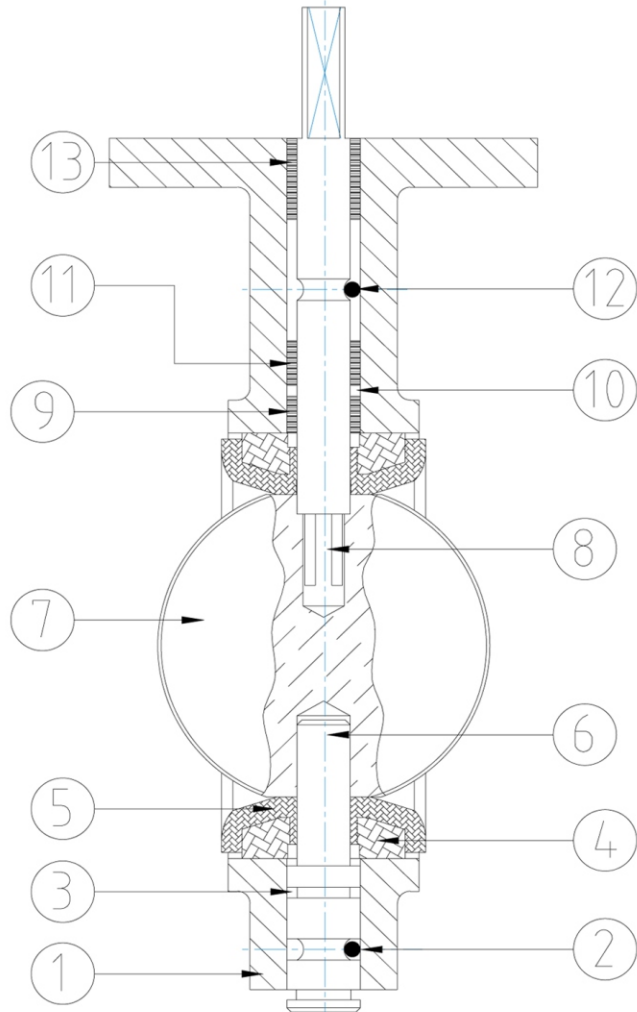

One piece body with extended neck allows clearance for flanges and up to 2 1/2 inch of insulation.

Primary stem seals are formed by preloaded contact between the disc and seat. A secondary seal is effected by having a stem diameter greater than the stem hole in resilient seat. These seals provide a non-wetted body and stem, eliminating the need for corrosion resistant body material.

Field replaceable, phenolic bonded cartridge is blowout proof, stretch resistant and non-collapsible, making it an ideal seat design for high velocity or vacuum service. Our resilient seat design eliminates the need for flange gaskets. Valve sizes 16" & above are supplied with metal seat back up rings.

- High strength, square drive (2" - 14") ensures a positive shaft to disc connection.
- Square drive offers direct ISO mounting of gear operator and automation equipment.
- Disc floats inside the seat for positive sealing and extended seat life.
- No pins or bolts exposed to flow.
- Offset shaft retainers mechanically retain the shaft in the body ensuring a blow out proof stem design.

MAX SEAL PERFORMANCE SERIES BUTTERFLY VALVE MODEL NUMBER CODES

Model	Body Material		Disc Material		Stem Material		Seat Material		Operator	
51	Ductile Iron	DI	Nylon Coated Ductile Iron	DI	Stainless 416	S6	EPDM	E	Lever	L
	Cast Iron	CI	Stainless 316	SS	Stainless 316	SS	BUNA	B	Gear	G
52	Stainless Steel	SS	Stainless 304	S4	Stainless 410	S0	VITON	V	Bare stem	N
					17-4Ph	S7	TEFLON	T	Actuator	A

ORDERING EXAMPLE BY PART NUMBER

Wafer	Cast Iron	Stainless 316	Stainless 316	BUNA	Lever
Model	Body	Disc	Stem	Seat	Operator
51	- CI	- SS	- SS	- B	- L

Performance / Design

Accurate and smooth machined profile of disc edge requires minimal deformation of the resilient elastomer liner to achieve a positive seal. The low deformation results in low torque, less wear of the seat liner and increased operational life. Max-Seal Performance Series Valves are bi-directionally bubble tight. They are marked with an arrow indicating the preferred high pressure sealing side.

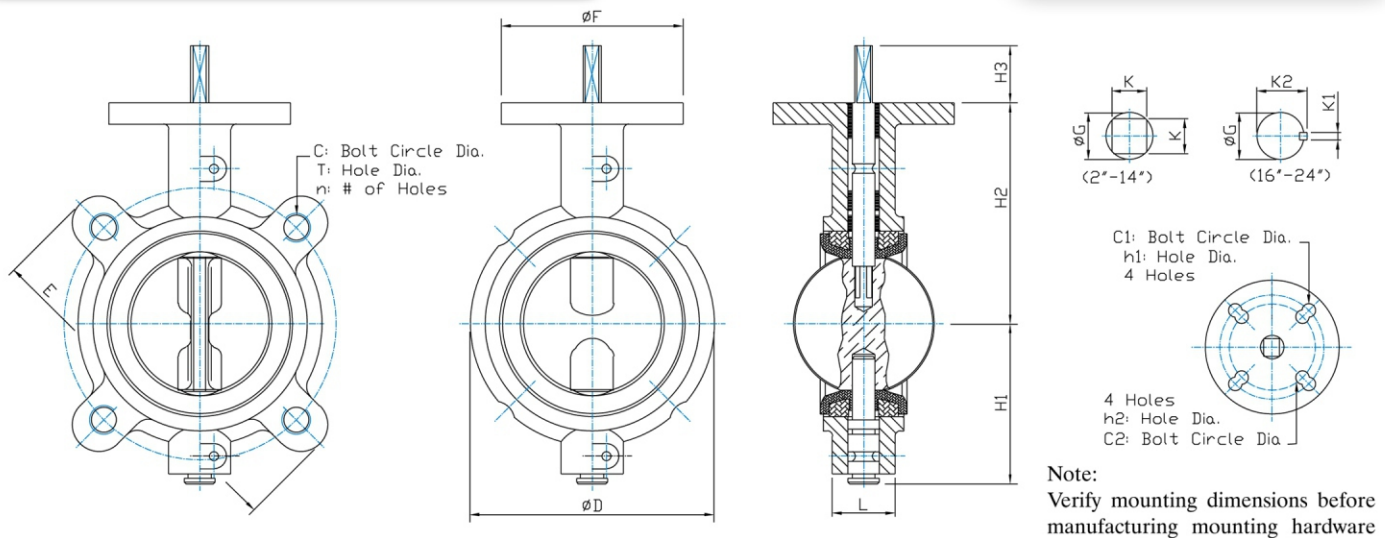

ANSI Class 125 Concentric Butterfly Valves

Size inch mm	D	E	L	H1	H2	H3	F	G	K	Flange Dimension			Mounting Base				Weight, lb			
										C	T	n	C1	h1	C2	h2	ISO	wafer	lug	
2	50	4.125	6.00	1.656	3.00	3.94	1.25	4.0	0.50	0.354	4.75	5/8-11unc	4	3.25	0.41	2.76	0.39	F07	5	7
2.5	65	4.875	7.00	1.75	3.34	4.59	1.25	4.0	0.50	0.354	5.50	5/8-11unc	4	3.25	0.41	2.76	0.39	F07	6.5	9
3	80	5.375	7.50	1.78	3.6	4.91	1.25	4.0	0.50	0.354	6.00	5/8-11unc	4	3.25	0.41	2.76	0.39	F07	7	9
4	100	6.875	9.00	2.05	4.28	6.00	1.25	4.0	0.625	0.433	7.50	5/8-11unc	8	3.25	0.41	2.76	0.39	F07	10.5	15.5
5	125	7.75	10.0	1.13	4.84	6.13	1.25	4.0	0.75	0.55	8.50	3/4-10unc	8	3.25	0.41	2.76	0.39	F07	13.5	20
6	150	8.75	11.0	2.19	5.34	6.69	1.25	4.0	0.75	0.55	9.50	3/4-10unc	8	3.25	0.41	2.76	0.39	F07	16.5	22.5
8	200	11.00	13.5	2.38	6.53	9.44	1.75	6.0	0.875	0.67	11.75	3/4-10unc	8	5.00	0.53	4.01	0.47	F10	31	40
10	250	13.38	16.0	2.58	7.84	11.22	1.75	6.0	1.125	0.87	14.25	7/8-9unc	12	5.00	0.53	4.01	0.47	F10	42.5	59.5
12	300	16.13	19.0	3.03	9.38	11.81	1.75	6.0	1.25	0.87	17.00	7/8-9unc	12	5.00	0.53	4.01	0.47	F10	65	93.5
14	350	17.16	20.63	3.07	10.5	14.49	1.77	6.0	1.24	0.87	18.75	1-8unc	12	5.00	0.53	4.01	0.47	F10	C/F	148
16	400	19.21	23.18	4.02	12.16	15.75	2.83	7.76	1.49	0.39x1.42	21.25	1-8unc	16	n/a	n/a	5.51	0.71	F14	C/F	215.5
18	450	21.22	25.00	4.49	12.91	16.61	2.83	7.76	1.69	0.39x1.61	22.75	1 1/8-7unc	16	n/a	n/a	5.51	0.71	F14	C/F	260
20	500	23.35	27.72	5.00	14.21	18.9	2.83	7.76	1.80	0.47x1.74	25.00	1 1/8-7unc	20	n/a	n/a	5.51	0.71	F14	C/F	384.5
24	600	32.44	32.68	6.06	18.07	22.12	3.23	10.87	2.13	0.63x2.15	29.50	1 1/4-7unc	20	n/a	n/a	6.50	0.87	F16	C/F	576.5

- Larger sizes available through 120", consult factory
- Pressure Ratings:
2"-12" 200 psi; 14"-24" 175 psi
- Lug Body for Dead End Service:
2"-12", 150 psi; 14"-24" 125 psi
- Higher Pressure Option:
250 WOG, Sizes 2" - 18", 220 WOG, Sizes 20" - 24"
with 17-4Ph stem & seat modification
- Vacuum Service up to 28" Hg
- Max-Seal valves are designed for bubble tight shutoff in either direction of flow. Each valve is factory tested to 110% of their pressure rating.

- Blow out proof stem design
- A heavy duty butterfly valve, designed for ANSI Class 125/150 flanges. These valves comply with MSS-SP25, MSS-SP67 and API609 specifications, as well as meeting the requirements of MIL-V-22133C (ship) Type 1, Class A-D
- Valve sizes up to 16" meet API 609; Sizes 18" - 24" meet API 609 also with fine thread drilling
- Positive Valve Position: When the handle is perpendicular to the pipe, the valve is shut. When the handle is parallel to the pipe, the valve is fully open. The orientation of the disc is indicated by a groove at the shaft end that is in line with the disc.

Max-Seal Performance Series offers longer service life, greater reliability, ease of parts replacement and interchangeability of componets.

HANDLE AND GEAR OPERATOR DIMENSIONS

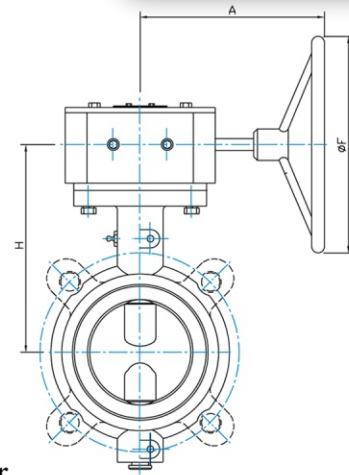
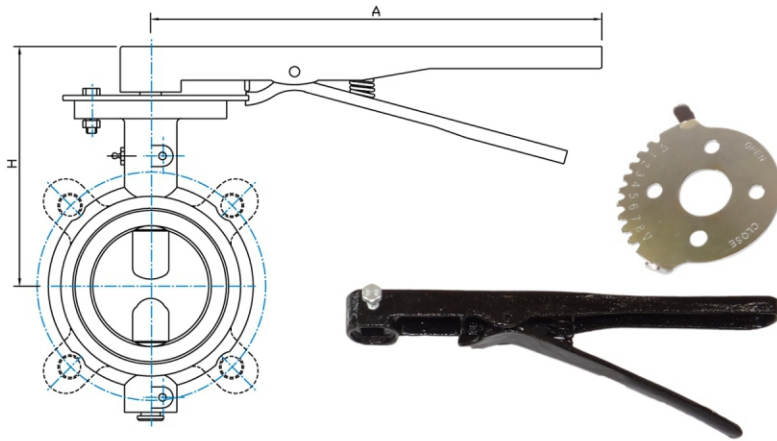

Lever-Lock 10 Position Type Handle

Gear Operator

SIZE	2"	2.5"	3"	4"	5"	6"	8"	10"	12"
H	5.19	5.84	6.16	7.25	7.38	7.94	11.19	12.97	13.56
A	10.5	10.5	10.5	10.5	10.5	10.5	14	14	20

SIZE	2"	2.5"	3"	4"	5"	6"	8"	10"	12"	14"	16"	18"	20"	24"
H	5.41	6.07	6.38	7.48	7.60	8.16	11.13	12.91	13.45	16.13	18.27	21.42	21.42	24.92
F	5.9	5.9	5.9	5.9	5.9	5.9	11.8	11.8	11.8	11.8	11.8	11.8	11.8	15.35
A	6	6	6	6	6	6	9.84	9.84	9.84	10.94	10.94	10.94	10.94	12.05

VALVE FLOW COEFFICIENTS & TECHNICAL DATA

Max-Seal Valves Are Ideally Suited for Actuated Applications

SEAT TEMPERATURE RANGE

Material	Temperature Range
Buna-N (NBR)	0° to 200°F
EPDM	-40° to 275°F
VITON	0° to 275°F
Neoprene	-60° to 200°F
Hypalon	-40° to 250°F
Silicon	-70 to 425°F
PTFE	-10° to 260°F



ACTUATOR MOUNTING

Max-Seal Offers A broad line of automation systems for precise proportioning or on-off control in either pneumatic or electrically powered units.

Cast Mounting Flange Accommodates All Types of Operators, offering two sets of slotted bolted circles ISO5211 and industry popular type. It is designed to accept direct actuator mounting, some sizes may require a spacer plate.

MAX SEAL Models 51, 52 CV Value

SIZE		Angle of Opening								
INCH	MM	10°	20°	30°	40°	50°	60°	70°	80°	90°
2	50	0.1	5	12	24	45	64	90	125	135
2 1/2	65	0.2	8	20	37	65	98	144	204	220
3	80	0.3	12	22	39	70	116	183	275	302
4	100	0.5	17	36	78	139	230	364	546	600
5	125	0.8	29	61	133	237	392	620	930	1022
6	150	2	45	95	205	366	605	958	1437	1579
8	200	3	89	188	408	727	1202	1903	2854	3136
10	250	4	151	320	694	1237	2047	3240	4859	5340
12	300	5	234	495	1072	1911	3162	5005	7505	8250

Performance Series Torque Valve

SIZE		Pressure Differential		
INCH	MM	50 psi	100 psi	200 psi
2	50	127	147	170
2 1/2	65	135	168	193
3	80	206	225	259
4	100	350	387	445
5	125	525	605	646
6	150	825	997	1147
8	200	1495	1864	2144
10	250	2420	3140	3611
12	300	3612	4767	5482

Streamlined Disc Design Reduces Pressure Drop and Maximizes Cv

These wet seating torque valves are figured for wet service defined as lubricated with clean non-abrasive line media



Max-Seal, Inc.
4815 West 5th St.
Lumberton, NC 28358

P.O. Box 1293
Lumberton, NC 28359
Website: www.maxsealinc.com

Tel: (910) 738-2866
Fax: (910) 739-1733
E-Mail: sales@maxsealinc.com