

N1—NUMBER OF HOLES
H1—HOLE DIA.
T—BOLT DIA.

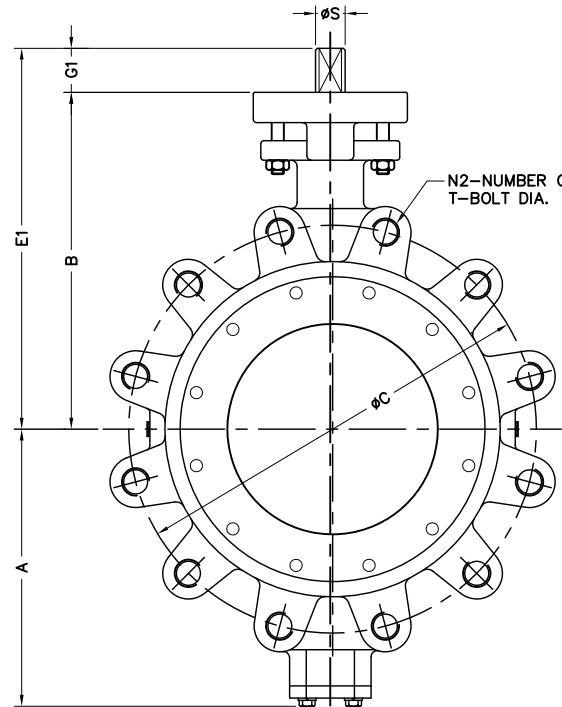

N2—NUMBER OF TAP HOLES
T—BOLT DIA.

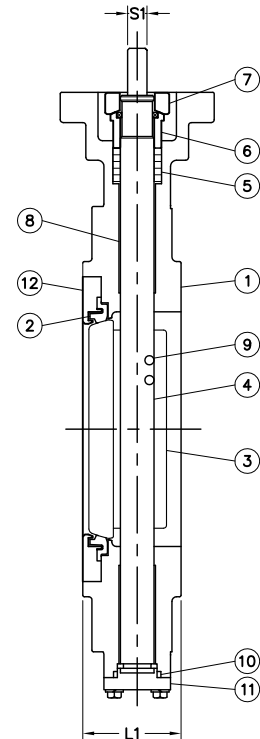

No.	Part Name
1	Body
2	Seat
3	Disc
4	Stem
5	Packing
6	Packing Gland
7	Gland Flange
8	Bush Bearing
9	Disc Pin
10	Cap Packing
11	Cap
12	Seat Retainer

Test Pressure(Psi-G) API 598		
	Hydraulic	Air
Shell	Seat	Seat
1125	825	-

File No.	P300WL02_06
Date of Issue	DO NOT SCALE
Date of Issue	2014-08-01

Title	HIGH PERFORMANCE VALVE 300# WAFER & LUGGED TYPE

Drawn by	Kim, S.S
Checked by	Kim, S.S
Approved by	Choi, J.Y

Date	
Revision	
No.	

PRATT INDUSTRIAL

THE INFORMATION CONTAINED IN THIS DRAWING IS THE SOLE PROPERTY OF PRATT INDUSTRIAL. IT IS TO BE USED ONLY FOR THE PART OR AS A WHOLE WITHOUT THE WRITTEN PERMISSION OF PRATT INDUSTRIAL IS PROHIBITED.

TOP WORKS

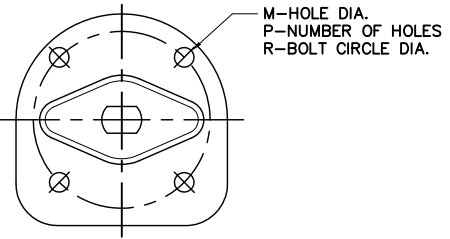

M—HOLE DIA.
P—NUMBER OF HOLES
R—BOLT CIRCLE DIA.

GEAR

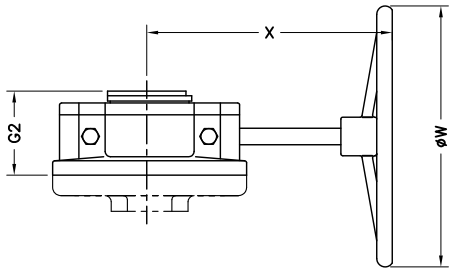

HAND LEVER

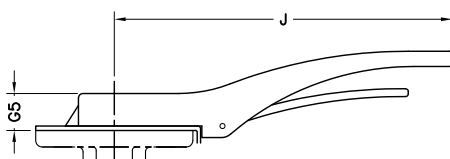

SIZE (inch)	A	B	G1	E1	L1	C	T	Flanged Drilling				TOP WORKS					Gear			Lever	
								Wafer		Lug N2	M	P	R	S1	S	G2	X	phi W	G5	J	
								N1	N2												H1
2	4.18	4.92	1.26	6.18	1.73	5.00	5/8"X11UNC	2	-	3/4	8	0.43	4	3.25	0.374	0.551	3.03	6.89	6.30	1.29	8.86
2.5	4.26	5.87	1.26	7.13	1.89	5.88	3/4"X10UNC	2	-	7/8	8	0.43	4	3.25	0.437	0.624	3.03	6.89	6.30	1.29	8.86
3	4.65	6.30	1.26	7.56	1.93	6.62	3/4"X10UNC	2	-	7/8	8	0.43	4	3.25	0.437	0.624	3.03	6.89	6.30	1.29	8.86
4	5.12	7.01	1.26	8.27	2.13	7.88	3/4"X10UNC	2	-	7/8	8	0.43	4	3.25	0.500	0.748	3.03	6.89	6.30	1.29	12.78
5	5.79	7.60	1.26	8.86	2.24	9.25	3/4"X10UNC	2	-	7/8	8	0.43	4	3.25	0.500	0.748	3.03	6.89	6.30	1.29	12.78
6	7.17	8.66	1.26	9.92	2.32	10.62	3/4"X10UNC	2	-	7/8	12	0.43	4	3.25	0.500	0.748	3.03	6.89	6.30	1.29	12.78

NOTE.
 1. DESIGN : ANSI B16.34 & API 609
 2. FLANGE CONNECTION : ANSI B16.5 CLASS 300
 3. FACE TO FACE DIMENSION : 2" 2.5" 5" - ISO 5752 SHORT
 3" 4" 6" - API 609 CATEGORY B